

STOP GLOBE VALVE TYPE 659

CHARACTERISTIC:

Diameter	-	15 -100 mm;
Pressure	-	400 bar;
Temperature	-	up to 600°C;
Medium	-	water, steam and other non-toxic, non aggressive liquid and gas media.

VERSIONS:

type / ends / body material / disc and disc ring / drive type

Example: 659 / --- / --- / --- / ---

Example: 659 / SW / U / L / ---

Ends	Sign	Body material	Sign	Disc and disc ring	Sign	Drive type	Sign
Standard-butt weld ends	---	(P250GH) C 22.8	---	Standard	---	Hand wheel	---
Socket weld	SW	16Mo3	U	Stellite ring	L	AUMA drive	NA
		13CrMo4-5	A			NWA drive	NW
		10CrMo9-10	B			MODACT drive	NM
		14MoV6-3	C			Pneumatic drive	NP

APPLICATION:

Stop globe valve (659) is designed to open and stop the flow. The valve is not supposed to be used as a regulating device. For regulation the version (684) with throttling plug should be applied.

DN 10 ÷ 15

DN 20 ÷ 50

DN 65 ÷ 100

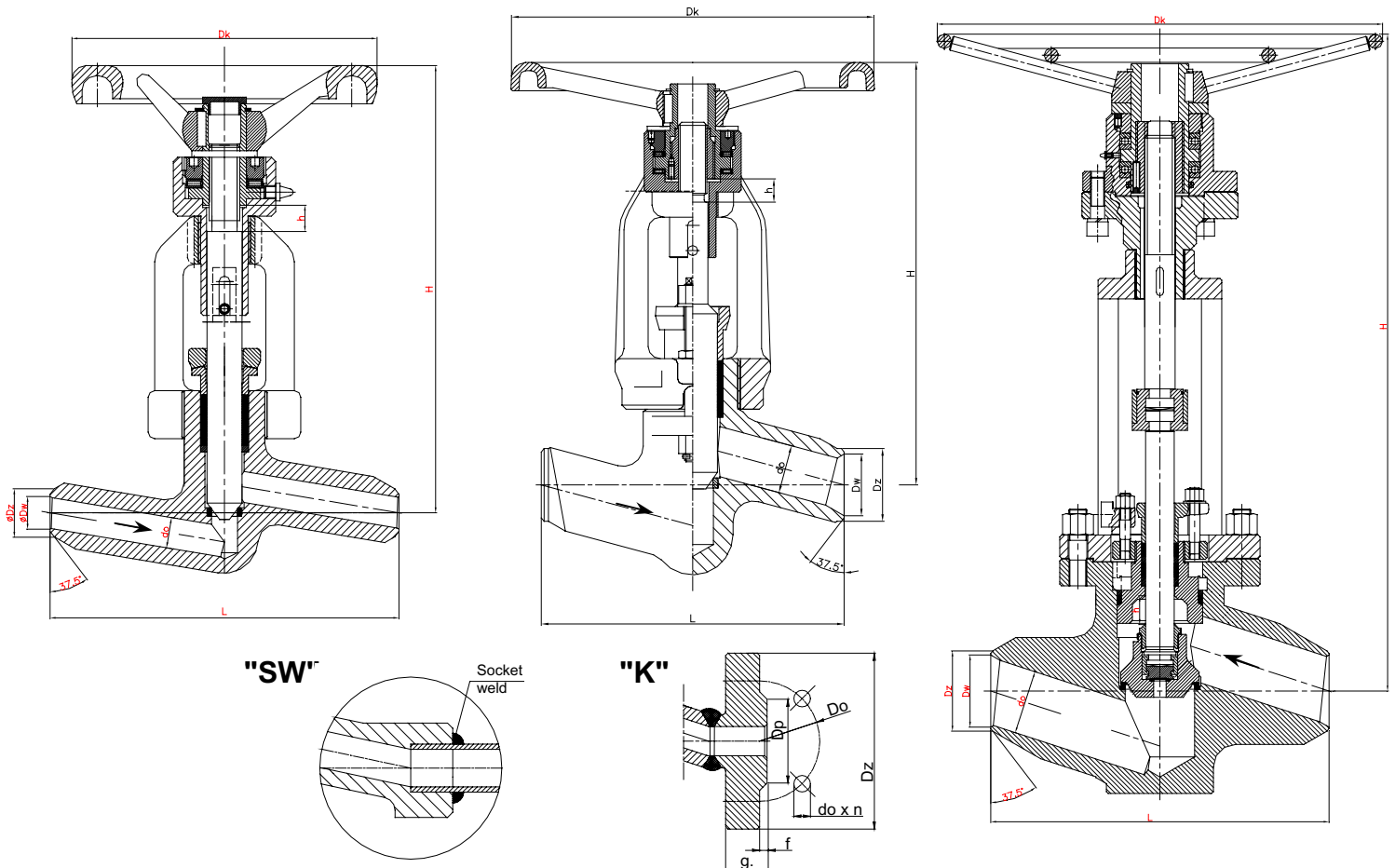

WK®

Info:

Italwarmi Srl

Via Mbro, 61 - 20097 San Donato Milanese - MI - Italy

Tel. +39 02 51 62 13 75

Fax. +39 02 51 62 90 70

e.mail: italwarmi@italwarmi.it

www.italwarmi.it

MATERIALS:

Versions	Standard	U	A	B	C
Parts	T _{MAX} 450°C	T _{MAX} 530°C	T _{MAX} 560°C	T _{MAX} 600°C	T _{MAX} 570°C
Body	(P250GH) C22.8 (1.0460)	16Mo3 (1.5415)	13CrMo4-5 (1.7335)	10CrMo9-10 (1.7380)	14MoV6-3 (1.7715)
Bonnet	DN 15-25 13CrMo4-5 (1.7335)		DN 32-125 G17CrMo5-5 (1.7357)		
Stem DN 15-65	X39CrNi17-1 (1.4122), X22CrMoV12-1 (1.4923)				
Disc DN 80-125	C22.8 (1.0460)	16Mo3 (1.5415)	13CrMo4-5 (1.7335)	10CrMo9-10 (1.7380)	14MoV6-3 (1.7715)
Seat ring	BT9; Stellite				
Upper stem	X17CrNi16-2 (1.4057), X39CrNi17-1 (1.4122)				
Wheel	Cast iron				

Special materials on request; modifications reserved.

DIMENSIONS:

Standard – butt weld ends						H	h	Dk	Końierzowe „K”							
DN	d	Dz	Dw	L	Weight				Dz	Dp	Do	do	n	L	g	f
10	10	20	10	160	3,00	205	12	140	-	-	-	-	-	-	-	-
15	14	28	17						145	45	100	22	4	230	30	2
20	20	35	21,5	160	9,00	266	19	200	-	-	-	-	-	260	-	-
25	24	44	29						180	68	130	26	4	260	38	2
32	30	50	33	300	30,00	418	23	360	-	-	-	-	-	300	-	-
40	38	62	40						220	88	165	30	4	300	48	3
50	44	77	49,5						235	102	180	30	8	350	52	3
65	62	91	62	340	-	714	45	GNR 700	290	122	225	33	8	400	64	3
80	76	117	81	380	-	637	36	GNR 500	305	138	240	33	8	450	68	3
100	92	144	102	430	-	720	50	GNR 500	370	162	295	39	8	520	80	3

Dimensions in mm; modifications reserved.

TECHNICAL DATA:

Body material	PN	Maximal working pressure at working temperature																	
		20°C	100°C	150°C	200°C	250°C	300°C	350°C	400°C	450°C	480°C	500°C	520°C	530°C	540°C	560°C	570°C	600°C	
(P250GH)C 22.8 (1.0460)	400	400,0	400,0	400,0	400,0	400,0	358,0	310,0	262,0	165,0	-	-	-	-	-	-	-	-	
16Mo3 (1.5415)	400	400,0	400,0	400,0	400,0	400,0	400,0	400,0	382,0	369,0	222,0	176,0	141,0	112,0	-	-	-	-	
13CrMo4-5 (1.7335)	400	400,0	400,0	400,0	400,0	400,0	400,0	400,0	400,0	400,0	327,0	276,0	224,0	186,0	146,0	95,0	79,0	-	
14MoV6-3 (1.7715)	400	400,0	400,0	400,0	400,0	400,0	400,0	400,0	400,0	400,0	400,0	400,0	355,0	312,0	269,0	205,0	174,0	-	
10CrMo9-10 (1.7380)	400	400,0	400,0	400,0	400,0	400,0	400,0	400,0	400,0	393,0	379,0	322,0	246,0	215,0	186,0	138,0	122,0	81,0	

MOUNTING AND OPERATING:

The valve can only be mounted and operated by skilled, properly trained and qualified personnel. Incorrect assembly or operation of the valve may have substantial impact on the entire system such as fluid leakage, reduction in system's function etc.

Before a valve is installed the pipeline must be clean from any mechanical impurities. The compatibility of critical parameters of the flow must be checked with the parameters of the valve. Stop globe valve can be mounted to a pipe-line in any position. The direction of flow should only comply with the arrow marked on the body. The valve should be operated strictly with its assign. In order to provide valve's reliability the following suggestions must be observed:

- medium flowing through the valve is supposed to be clean out of any mechanical impurities;
- the valve must be protected from any mechanical damages during its work;
- nominal parameters marked on the valve must be observed.