

# CHECK VALVE ACID-PROOF ANGULAR TYPE ZZFA40

## CHARACTERISTIC:

- Diameter - 15 -250 mm;
- Pressure - 40 bar (flanged may be drilled for 6, 10, 16, 25, bar)
- Temperature - up to 250°C for acids, bases and other aggressive media;
- up to 550°C for non-toxic media; (with PTFE sealing up to 200°C);
- Medium - acids, liquors, water, steam and other non-toxic and non aggressive liquid and gas media, engine fuel.

## VERSIONS:

**type - body material / ends / disc and disc rings / others**

**Example: ZZFA40 / --- / --- / ---**

**Example: ZZFB40 / S / P / ---**

Type - body material	Sign	Ends	Sign	Disc and disc rings	Sign	Others	Sign
X6CrNi18-10 or GX5CrNi19-10	<b>ZZFA40</b>	Standard - flanged	---	Standard	---	-----	---
		Butt weld ends	<b>S</b>	PTFE ring	<b>P</b>		
X2CrNiMo17-12-2 or GX5CrNiMo19-11-2	<b>ZZFB40</b>	Socketed weld	<b>SW</b>	NBR ring	<b>N</b>		
		Threaded	<b>G</b>				

## APPLICATION:

The check valve is designed to keep pipeline safe from returning the medium.

**DN 15 - 80**

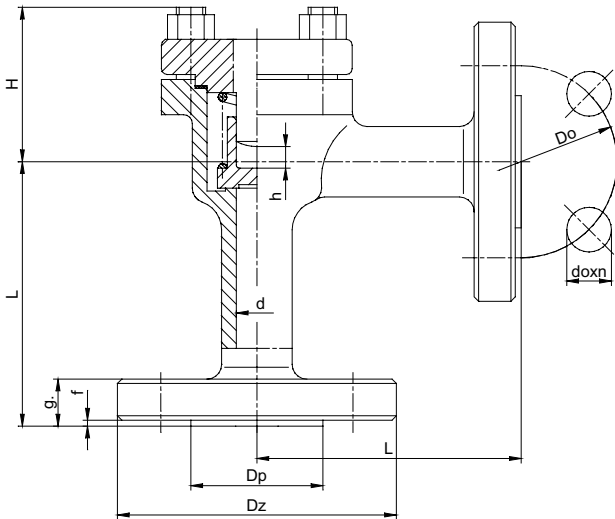

**DN 100 - 250**

**"S"**

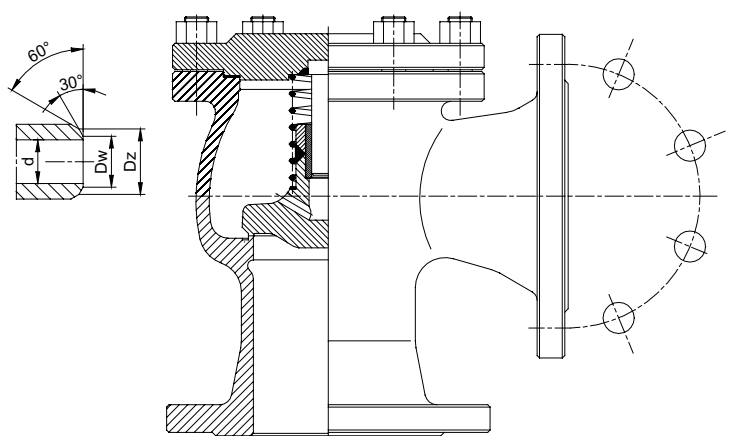

**"SW"**

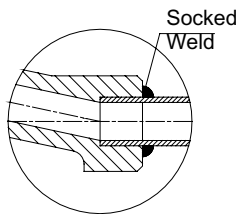

**"G"**

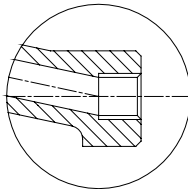

T<sub>MAX</sub> 200°C

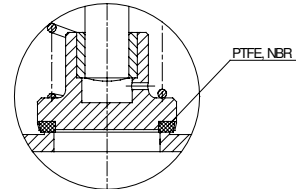

# WK®

Info:

**Italwarmi Srl**

Via Mbro, 61 - 20097 San Donato Milanese - MI - Italy

Tel. +39 02 51 62 13 75

Fax. +39 02 51 62 90 70

e.mail: [italwarmi@italwarmi.it](mailto:italwarmi@italwarmi.it)

[www.italwarmi.it](http://www.italwarmi.it)

## MATERIALS:

Versions	ZZFA40	ZZFB40	ZZFA40	ZZFB40
Parts	DN 15 - 80		DN 100 - 250	
Body, bonnet	X6CrNiTi18-10 (1.4541)	X2CrNiMo17-12-2 (1.4404)	GX5CrNi19-10 (1.4308)	GX5CrNiMo19-11-2 (1.4408)
Disc	X6CrNiTi18-10 (1.4541)	X2CrNiMo17-12-2 (1.4404)	X6CrNiTi18-10 (1.4541)	X2CrNiMo17-12-2 (1.4404)
Spring	X6CrNiTi18-10 (1.4541)			
Gasket	Graft			

Special materials on request; modifications reserved.

## DIMENSIONS:

DN	Standard - flanged															With butt weld ends			
	PN 40											PN 16				Dz	Dw	Weight	
	Dz	Dp	Do	do	n	L	g.	f	H	h	Weight	Dz	Dp	Do	do				n
15	95	45	65	14	4	90	16	2	65	9	2,50	95	45	65	14	4	22	17	0,80
20	105	58	75	14	4	95	18	2	65	9	3,50	105	58	75	14	4	28	22	1,20
25	115	68	85	14	4	100	18	2	65	9	3,90	115	68	85	14	4	35	28,5	1,25
32	140	78	100	18	4	105	18	2	75	13	6,80	140	78	100	18	4	44	37	2,90
40	150	88	110	18	4	115	18	3	90	15	8,90	150	88	110	18	4	50	43	4,40
50	165	102	125	18	4	125	20	3	105	18	10,00	165	102	125	18	4	62	54	4,20
65	185	122	145	18	8	145	22	3	130	22	13,50	185	122	145	18	4	77	69	5,80
80	200	138	160	18	8	155	24	3	155	26	21,00	200	138	160	18	8	91	81	11,50
100	235	162	190	22	8	175	24	3	165	32	41,20	220	158	180	18	8	117	104	28,80
125	270	188	220	26	8	200	26	3	175	40	51,60	250	184	210	18	8	144	130,5	34,60
150	300	218	250	26	8	225	28	3	186	46	62,00	285	212	240	22	8	172	156,5	40,90
200	375	285	320	30	12	275	34	3	205	58	125,00	340	268	295	22	12	223	204,5	86,70
250	450	306	385	33	12	325	38	3	290	70	165,00	405	320	355	26	12	278	256,5	109,50

Dimensions in mm; modifications reserved.

## TECHNICAL DATA:

Body material	Medium	PN	Maximal working pressure at working temperature																
			20°C	100°C	150°C	200°C	250°C	300°C	350°C	400°C	450°C	480°C	500°C	510°C	520°C	530°C	540°C	550°C	
			bar																
X6CrNiTi18-10 (1.4541)	aggressive media	40	40,0	39,6	37,3	35,4	33,7	-	-	-	-	-	-	-	-	-	-	-	
		40	40,0	36,3	32,7	29,9	27,6	-	-	-	-	-	-	-	-	-	-	-	
X6CrNiTi18-10 (1.4541)	non aggressive media	40	40,0	39,6	37,3	35,4	33,7	31,8	30,6	29,7	29,0	28,7	28,3	28,0	27,8	27,5	27,2	27,0	
		40	40,0	36,3	32,7	29,9	27,6	25,7	24,5	23,8	23,3	23,0	22,8	22,0	19,5	18,9	18,0	17,5	

## MOUNTING AND OPERATING:

*The valve can only be mounted and operated by skilled, properly trained and qualified personnel. Incorrect assembly or operation of the valve may have substantial impact on the entire system such as fluid leakage, reduction in system's function etc.*

Before a valve is installed the pipeline must be clean from any mechanical impurities. The compatibility of critical parameters of the flow must be checked with the parameters of the valve. Check valve can be mounted to a pipe-line in any position. The direction of flow should only comply with the arrow marked on the body. The valve should be operated strictly with its assign. In order to provide valve's reliability the following suggestions must be observed:

- medium flowing through the valve is supposed to be clean out of any mechanical impurities;
- the valve must be protected from any mechanical damages during its work;
- nominal parameters marked on the valve must be observed.