

# CHECK VALVE TYPE 292

## CHARACTERISTIC:

Diameter	-	15 -300 mm;
Pressure	-	40 bar (flanges may be drilled for PN 6, 10, 16, 25 bar);
Temperature	-	up to 560°C (with PTFE sealing up to $\leq 200^{\circ}\text{C}$ );
Medium	-	water, steam and other non-toxic, non aggressive liquid and gas media and engine fuel, sea water.

## VERSIONS:

**type / ends / body material / disc and disc ring / others**

Example: 292 / --- / --- / --- / ---

Example: 292 / S / U / P / WM

Ends	Sign	Body material	Sign	Disc and disc ring	Sign	Others	Sign
Standard - flanged	---	(P250GH) C 22.8 or GP240GH	---	Standard	---		
Butt weld ends	S			PTFE ring	P	Sea version	WM
Socket weld	SW	16Mo3 or G20Mo5	U	NBR ring	N		
Threaded	G	13CrMo4-5 or G17CrMo5-5	A	STELLIT ring	L		

## APPLICATION:

The check valve is designed to keep pipeline safe from returning the medium.

DN 15 - 50

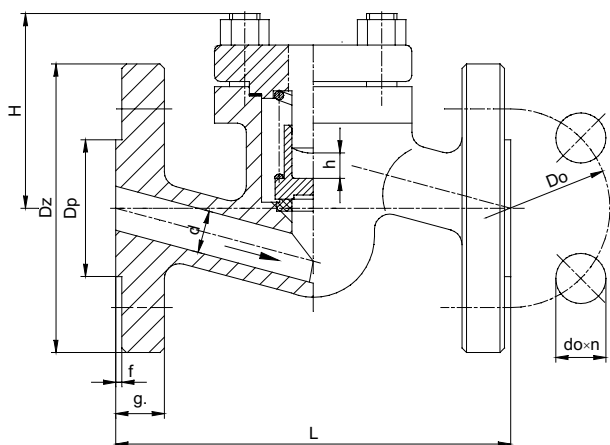

DN 65 - 300

"S"

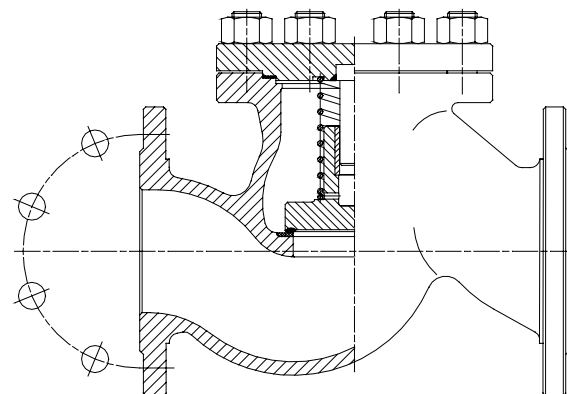
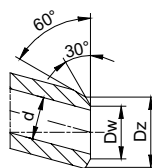

T<sub>MAX</sub> 200°C

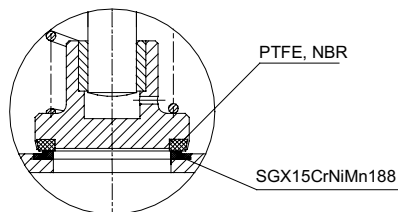

"G"

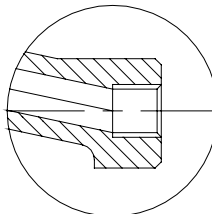

"SW"

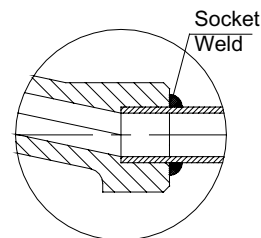

# WK®

Info:

**Italwarmi Srl**

Via Mbro, 61 - 20097 San Donato Milanese - M - Italy

Tel. +39 02 51 62 13 75

Fax. +39 02 51 62 90 70

e.mail: [italwarmi@italwarmi.it](mailto:italwarmi@italwarmi.it)

[www.italwarmi.it](http://www.italwarmi.it)

## MATERIALS:

Versions	Standard	U	A	Standard	U	A
Parts	T <sub>MAX</sub> 450°C	T <sub>MAX</sub> 530°C	T <sub>MAX</sub> 560°C	T <sub>MAX</sub> 450°C	T <sub>MAX</sub> 530°C	T <sub>MAX</sub> 560°C
	DN 15 - 50			DN 65 - 300		
Body, bonnet	P250GH) C22.8 (1.0460)	16Mo3 (1.5415)	13CrMo4-5 (1.7335)	GP240GH (1.0619)	G20Mo5 (1.5419)	G17CrMo5-5 (1.7357)
Seat ring	G 18 8 Mn (1.4370) or Stellite, or CW306G					
Disc	X30Cr13 (1.4028), X17CrNi16-2 (1.4057), P245GH (1.0352), CW306G, 13CrMo4-5 (1.7335)					
Disc ring	G 18 8 Mn (1.4370) or Stellite, CW306G, PTFE, NBR					
Spring	51CrV4 (1.2241)					
Gasket	Grafit					

Special materials on request; modifications reserved.

## DIMENSIONS:

DN	Standard - flanged															With butt weld ends			
	PN 40										PN 16					Dz	Dw	Weight	
	Dz	Dp	Do	do	n	L	g	f	H	h	Weight	Dz	Dp	Do	do				n
15	95	45	65	14	4	130	16	2	65	10	2,50	95	45	65	14	4	22	17	1,10
20	105	58	75	14	4	150	18	2	65	10	2,90	105	58	75	14	4	28	22	1,40
25	115	68	85	14	4	160	18	2	65	10	3,30	115	68	85	14	4	35	28,5	1,70
32	140	78	100	18	4	180	18	2	85	15	6,80	140	78	100	18	4	44	37	3,60
40	150	88	110	18	4	200	18	3	95	17	9,00	150	88	110	18	4	50	43	4,70
50	165	102	125	18	4	230	20	3	110	21	10,50	165	102	125	18	4	62	54	6,10
65	185	122	145	18	8	290	22	3	155	22	17,50	185	122	145	18	4	77	69	12,70
80	200	138	160	18	8	310	24	3	170	26	27,00	200	138	160	18	8	91	81	18,50
100	235	162	190	22	8	350	24	3	195	32	41,00	220	158	180	18	8	117	104	36,00
125	270	188	220	26	8	400	26	3	200	40	54,00	250	184	210	18	8	144	130,5	49,00
150	300	218	250	26	8	480	28	3	225	44	90,00	285	212	240	22	8	172	156,5	76,00
200	375	285	320	30	12	600	34	3	270	60	150,00	340	268	295	22	12	223	204,5	140,00
250	450	306	385	33	12	730	38	3	290	70	195,00	405	320	355	26	12	278	256,5	165,00
300	515	410	450	33	16	850	42	3	410	130	360,00	460	370	410	26	12	329	306,5	280,00

Dimensions in mm; modifications reserved.

## TECHNICAL DATA:

Body material	PN	Maximal working pressure at working temperature																
		20°C	100°C	150°C	200°C	250°C	300°C	350°C	400°C	450°C	480°C	500°C	510°C	520°C	530°C	540°C	550°C	560°C
(P250GH)C 22.8 (1.0460)	40	40,0	37,1	35,2	33,3	30,5	27,6	25,7	23,8	13,1	-	-	-	-	-	-	-	-
16Mo3 (1.5415)	40	40,0	40,0	40,0	40,0	39,0	34,3	32,4	30,5	29,5	22,4	17,7	14,5	11,2	9,0	-	-	-
13CrMo4-5 (1.7335)	40	40,0	40,0	40,0	40,0	40,0	39,8	38,1	36,2	34,3	29,3	26,1	22,0	17,9	14,9	11,6	9,3	7,6
GP240GH (1.0619)	40	40,0	37,1	35,2	33,3	30,5	27,6	25,7	23,8	13,1	-	-	-	-	-	-	-	-
G20Mo5 (1.5419)	40	40,0	40,0	40,0	40,0	39,0	34,3	32,4	30,5	29,5	22,4	17,7	14,5	11,2	9,0	-	-	-
G17CrMo5-5 (1.7357)	40	40,0	40,0	40,0	40,0	40,0	39,8	38,1	36,2	34,3	29,3	26,1	22,0	17,9	14,9	11,6	9,3	7,6

## MOUNTING AND OPERATING:

*The valve can only be mounted and operated by skilled, properly trained and qualified personnel. Incorrect assembly or operation of the valve may have substantial impact on the entire system such as fluid leakage, reduction in system's function etc.*

Before a valve is installed the pipeline must be clean from any mechanical impurities. The compatibility of critical parameters of the flow must be checked with the parameters of the valve. Check valve can be mounted to a pipe-line in any position. The direction of flow should only comply with the arrow marked on the body. The valve should be operated strictly with its assign. In order to provide valve's reliability the following suggestions must be observed:

- medium flowing through the valve is supposed to be clean out of any mechanical impurities;
- the valve must be protected from any mechanical damages during its work;
- nominal parameters marked on the valve must be observed.