

STOP GLOBE VALVE ACID-PROOF TYPE ZKA40

CHARACTERISTIC:

Diameter	-	15 -300 mm;
Pressure	-	40 bar (flanged may be drilled for 6, 10, 16, 25, bar)
Temperature	-	up to 250°C for acids, bases and other aggressive media;
	-	up to 550°C for non-toxic media; (with PTFE sealing up to 200°C);
Medium	-	acids, liquors, water, steam and other non-toxic and non aggressive liquid and gas media, engine fuel.

VERSIONS:

type - body material / ends / disc and disc ring / others

Example: ZKA40 / --- / --- / ---

Example: ZKB40 / S / R / ---

Type - body material	Sign	Ends	Sign	Disc and disc ring	Sign	Drive type	Sign	Others	Sign
X6CrNi18-10 or GX5CrNi19-10	ZKA40	Standard - flanged	---	Standard	---	Hand wheel	---	-----	---
X2CrNiMo17-12-2 or GX5CrNiMo19-11-2	ZKB40	Butt weld ends	S	Throttle plug	R	AUMA drive	NA		
		Socket weld	SW	Throttle plug	RR	NWA drive	NW		
		Threaded	G	Throttle plug	Q	MODACT drive	NM		
				PTFE ring	P	Pneumatic drive	NP		
				NBR ring	N				

APPLICATION:

Stop globe valve is designed to open and stop the flow. The valve is not supposed to be used as a regulating device. For regulation the version „R” with throttling plug should be applied.

DN 15 - 50

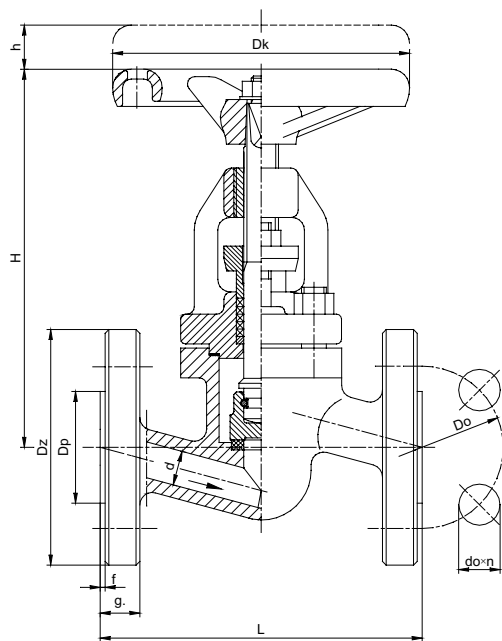

DN 65 - 300

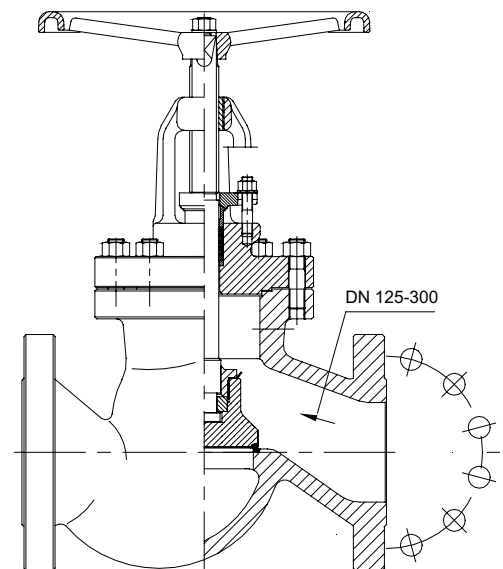

"SW"

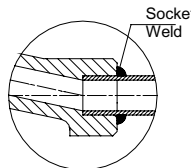

"G"

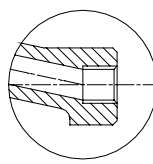

"S"

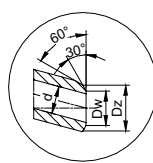

Throttle plug
"R"

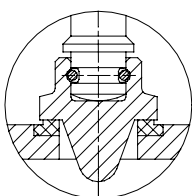

Throttle plug
"RR"

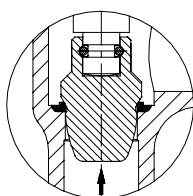

Throttle plug
"Q"

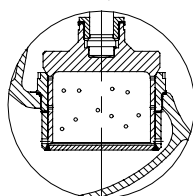

Equilibrating disc
DN 125-300

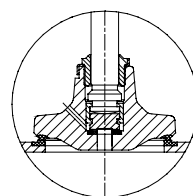

T_{max} 200°C

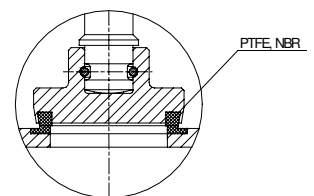

WK®

Info:

Italwarmi Srl

Via Mbro, 61 - 20097 San Donato Milanese - MI - Italy

Tel. +39 02 51 62 13 75

Fax. +39 02 51 62 90 70

e.mail: italwarmi@italwarmi.it

www.italwarmi.it

MATERIALS:

Versions	ZKA40	ZKB40	ZKA40	ZKB40
Parts	DN 15 - 50		DN 65 - 300	
Body, bonnet	X6CrNiTi18-10 (1.4541)	X2CrNiMo17-12-2 (1.4404)	GX5CrNi19-10 (1.4308)	GX5CrNiMo19-11-2 (1.4408)
Disc	X6CrNiTi18-10 (1.4541)	X2CrNiMo17-12-2 (1.4404)	X6CrNiTi18-10 (1.4541)	X2CrNiMo17-12-2 (1.4404)
Stem	X6CrNiTi18-10 (1.4541)	X2CrNiMo17-12-2 (1.4404)	X6CrNiTi18-10 (1.4541)	X2CrNiMo17-12-2 (1.4404)
Packing rings, gasket	Grafit			
Wheel	Cast iron			

Special materials on request; modifications reserved.

DIMENSIONS:

DN	Standard - flanged																	With butt weld ends		
	PN 40												PN 16					Dz	Dw	Weight
	Dz	Dp	Do	do	n	L	g.	f	H	h	Dk	Weight	Dz	Dp	Do	do	n			
15	95	45	65	14	4	130	16	2	155	13	120	3,80	95	45	65	14	4	22	17	2,40
20	105	58	75	14	4	150	18	2	155	13	120	4,50	105	58	75	14	4	28	22	2,50
25	115	68	85	14	4	160	18	2	155	13	120	5,00	115	68	85	14	4	35	28,5	2,80
32	140	78	100	18	4	180	18	2	195	15	160	9,50	140	78	100	18	4	44	37	6,20
40	150	88	110	18	4	200	18	3	205	19	160	10,70	150	88	110	18	4	50	43	5,90
50	165	102	125	18	4	230	20	3	215	24	160	12,80	165	102	125	18	4	62	54	8,10
65	185	122	145	18	8	290	22	3	245	30	200	28,40	185	122	145	18	4	77	69	17,50
80	200	138	160	18	8	310	24	3	300	40	250	36,70	200	138	160	18	8	91	81	23,50
100	235	162	190	22	8	350	24	3	402	45	320	52,50	220	158	180	18	8	117	104	40,80
125	270	188	220	26	8	400	26	3	436	55	280	70,20	250	184	210	18	8	144	130,5	67,70
150	300	218	250	26	8	480	28	3	496	65	320	106,50	285	212	240	22	8	172	156,5	86,60
200	375	285	320	30	12	600	34	3	576	75	400	207,20	340	268	295	22	12	223	204,5	171,40
250	450	345	385	33	12	730	38	3	590	130	400	325,00	405	320	355	26	12	278	256,5	276,60
300	515	410	450	33	16	850	42	3	730	205	600	530,00	460	370	410	26	12	329	306,5	456,00

Dimensions in mm; modifications reserved.

TECHNIOCAL DATA:

Body material	Medium	PN	Maximal working pressure at working temperature															
			20°C	100°C	150°C	200°C	250°C	300°C	350°C	400°C	450°C	480°C	500°C	510°C	520°C	530°C	540°C	550°C
X6CrNiTi18-10 (1.4541)	aggressive media	40	40,0	39,6	37,3	35,4	33,7	-	-	-	-	-	-	-	-	-	-	-
		40	40,0	36,3	32,7	29,9	27,6	-	-	-	-	-	-	-	-	-	-	-
GX5CrNi19-10 (1.4308)	non aggressive media	40	40,0	39,6	37,3	35,4	33,7	31,8	30,6	29,7	29,0	28,7	28,3	28,0	27,8	27,5	27,2	27,0
		40	40,0	36,3	32,7	29,9	27,6	25,7	24,5	23,8	23,3	23,0	22,8	22,0	19,5	18,9	18,0	17,5

DN	Kv "R"														
	15	20	25	32	40	50	65	80	100	125	150	200	250	300	
ZKA40R	3,8	6,2	8,7	15,5	27	38	69	104	165	240	332	570	959	1580	

MOUNTING AND OPERATING:

MOUNTING OF VALVE AND ITS SERVICE SHOULD BE MADE BY ORGANIZATION THAT HAS RIGHTS TO MAKE THAT KINDE OF WORKS. THE PERSONEL OF THOSE ORGANIZATIONS IS SUPPOSED TO BE QUALIFIED.

Before valve will be installed the pipeline must be clean from any mechanical impurities. The compatibility of critical parameters of flow must be checked with the parameters of valve. Stop globe valve can be mounted to a pipe-line in any position. The direction of flow should only comply with the arrow marked on the body. The valve should be operate strictly with its assign. To make valve unfailling you must observe the following suggestions:

- medium flowing through the valve is supposed to be clean out of any mechanical impurities.
- the valve must be protected from any mechanical damages during his work.
- parameters should be the same as on the valve.